

PREMIUM 45°

DISTRIBUTORS



- Inverted cone bottom design to minimize dust and moisture build up. Self cleaning design requiring very little maintenance.

- Brush Seal Sweep helps prevent cross contamination. In addition it sweeps the inverted cone bottom every time you move the inner spoon, manually cleaning the distributor from the ground!

- Spring tensioned locking mechanism for perfect alignment to avoid cross contamination.

FEATURES:

- Manual Operation with EZ – Control
- Painted, powder coated, or hot dipped galvanized
- Hinged inspection door
- 10 ga outlets, 3/16" inner spout standard

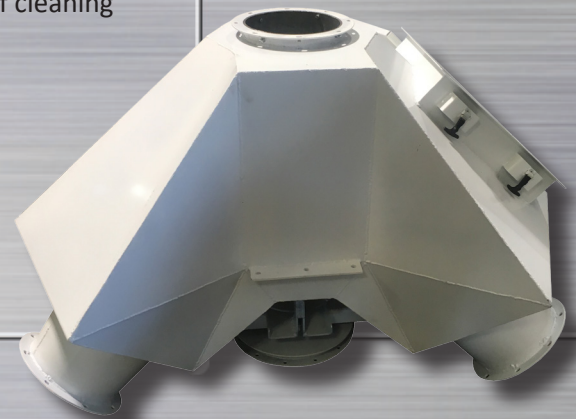

- Unique Flat Back / Wing Back compact design provides added benefits for spouting in a wider area up to 225° compared to only 180° of a conventional flat back distributor.

DIMENSION TABLE (INCHES)

NOM SIZE	NUMBER OUTLETS	A	B	C	D
8	4	30 15/16	22 9/16	N/A	12
	6	30 15/16	22 9/16	17 15/16	12
	8	42 15/16	34 9/16	N/A	12
	10	42 15/16	34 9/16	20 13/16	12
10	4	35 9/16	26 3/4	N/A	12
	6	35 9/16	26 3/4	20 9/16	12
	8	50 7/16	41 11/16	N/A	12
	10	50 7/16	41 11/16	25 5/16	12
12	4	40 7/16	31 3/16	N/A	12
	6	40 7/16	31 3/16	25 13/16	12
	8	52 15/16	43 11/16	N/A	15
	10	52 15/16	43 11/16	27 3/16	15
14	4	45 5/16	35 11/16	N/A	14
	6	45 5/16	35 11/16	20 3/4	14
	8	60 5/16	50 11/16	N/A	16
	10	60 5/16	50 11/16	31 11/16	16

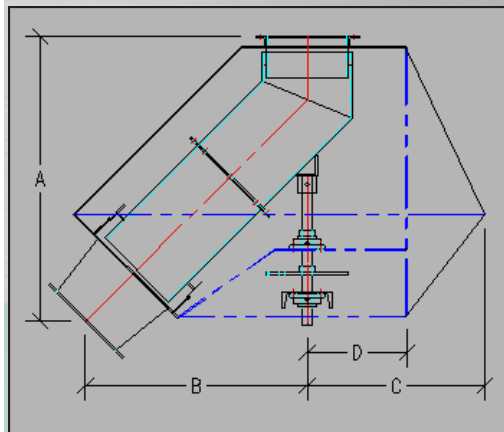

Material Handling
Equipment Sales, Inc.

310 S. Section Line Rd.
Delaware, OH 43015

989-430-4005

Fax: 740-363-9004

www.mhesi.com